

# Chapter 1

## General Provisions

---

### *Contents*

- 1.1. *Purpose and Applicability*
- 1.2. *Definitions*

- 1.1. PURPOSE AND APPLICABILITY.** An Ordinance dividing Boone County into districts, regulating and restricting the location and use of buildings, structures and land for trade, industry, residence and other uses within these districts; regulating and restricting the intensity of such uses, and establishing setback lines in order to promote the orderly development of the unincorporated portion of Boone County in accordance with the Official Comprehensive Plan and Illinois Compiled Statutes.

In addition, it is the intent of Boone County to conserve, to protect and to encourage the development and improvement of its prime agricultural land for the production of food and other agricultural products. It is also the intent of Boone County to conserve and to protect prime agricultural land as valued natural and economic resources. Agricultural land is the county's most valuable economic resource and its long term viability is desirable for future operations. Agriculture in many parts of the County is under pressure from expanding growth areas. This pressure takes the form of uncoordinated development in agricultural areas, encourages conflicts in uses of land, and creates higher costs for public services. As scattered development extends into productive farm areas, viable farming may be inhibited by raising real estate taxes and reluctance to make long term investments in farm improvements. Prime agricultural lands constitute unique and irreplaceable land and economic resources of statewide, nationwide and worldwide importance. It is the intent of this Ordinance to provide a means by which agricultural land may be wisely protected as a valuable segment of the County. Agricultural districts have been established herein in accordance with the Boone County Comprehensive Plan for the following purposes:

- A. To conserve resources in land and land use values.
- B. To protect, strengthen and maintain the economic base that agricultural pursuits provide the County.
- C. To avoid incompatibilities and conflicts resulting from a mixture of rural and urban land uses.
- D. To prevent haphazard or premature urbanization by guiding growth in an orderly fashion.
- E. To prevent an unfair shifting of construction and service costs to agriculture landowners.
- F. To maximize police, fire and health protection.
- G. To maintain and enhance rural community values.

Be it ordained by the Boone County Board, Boone County, Illinois as follows:

- 1.1.1. Short Title.** This Ordinance may be cited as the "Boone County Zoning Ordinance," the "Zoning Ordinance," or the "Ordinance."

**1.1.2. Scope of Regulations.** The regulations set forth in this Ordinance within each district shall be minimum regulations and shall apply uniformly to each class or kind of structure or land, except as hereinafter provided and except as variations are applied through Section 2.8.

- A. No building, structure, or land shall hereafter be used or occupied, and no building or structure or part thereof, shall hereafter be constructed, moved, or structurally altered except in conformity with all of the regulations herein specified for the district in which it is located.
- B. No building or structure shall hereafter be erected or altered:
  - 1. to exceed the height or bulk;
  - 2. to accommodate or house a greater number of families;
  - 3. to occupy a greater percentage of lot area than permitted;
  - 4. to have narrower or smaller rear yards, front yards, side yards, or other open spaces than herein required; or in any other manner contrary to the provisions of this Ordinance.
- C. No part of a yard, or other open space, or off-street parking or loading space required in connection with any building for the purpose of complying with this Ordinance, shall be included as part of a yard, open space, or off-street parking or loading space similarly required for any other building.
- D. No yard or lot existing prior to the adoption of this Ordinance shall be reduced in dimension or area below the minimum requirements set forth herein. Yards or lots created after the adoption of this Ordinance shall meet at the least the minimum requirements established by this Ordinance.

**1.1.3. Exempted Uses.**

- A. The following uses are exempt from this Zoning Ordinance and permitted in any district (although they may still be subject to the County Building Code and Subdivision Regulations): poles, towers, wires, cables, conduits, vaults, laterals, pipes, mains, valves or any other similar distributing equipment for telephone or other communications, electric power, gas, water and sewer lines, provided that the installations shall conform to Illinois Compiled Statutes, the Federal Communications Commission, and Federal Aeronautics Administration rules and regulations and the regulations of other authorities having jurisdiction.
- B. The provisions of this Ordinance shall not be exercised so as to impose regulations or require permits with respect to land used or to be used for agricultural purposes, or with respect to the erection, maintenance, repair, alteration, remodeling or extension of buildings or structures used or to be used for agricultural purposes upon such land, except that such buildings or structures for agricultural purposes may be required to conform to building or setback lines.

**1.1.4. Grandfathered Right to Develop or Use Property.**

- A. An existing lot of record at the time of adoption of this Ordinance, which does not meet the minimum lot area, width, depth, and road frontage requirements contained in this Ordinance, shall be developed in accordance with the use district in which it is located under this Ordinance, but may be developed in accordance with the lot area, width, depth, and road frontage requirements of the Zoning Ordinance adopted April 11, 1984.
- B. A lot which was a lot of record prior to April 11, 1984, which does not meet the minimum lot area, width, depth, and road frontage requirements contained in this

Ordinance, shall be developed in accordance with the use district in which it is located under this Ordinance, but may be developed in accordance with the lot area, width, depth, and road frontage requirements of the Zoning Ordinance adopted July 12, 1973.

- C. A lot which was a lot of record prior to July 12, 1973, which does not meet the minimum lot area, width, depth, and road frontage requirements contained in this Ordinance, shall be developed in accordance with the use district in which it is located under this Ordinance, but may be developed in accordance with the lot area, width, depth, and road frontage requirements of the Ordinance adopted May 14, 1958.
- D. All undeveloped lots of record in the A 1 district in lawful existence prior to May 10, 1978 may be developed with one single family residence per lot provided that other provisions of this Ordinance and other applicable Boone County codes and ordinances are met.
- E. None of the foregoing shall be construed to relieve the owner or builder from providing an adequate sewage treatment system.

**1.1.5. Severability.** This Ordinance and any amendment hereto and the various parts, sections, subsections and clauses thereof, are hereby declared to be severable. If any part, sentence, paragraph, subsection, section or clause is adjudged unconstitutional or invalid, it is hereby provided that the remainder of this Ordinance or amendment hereto shall not be affected thereby. If any part, sentence, paragraph, subsection, section or clause is adjudged unconstitutional by a court of competent jurisdiction or invalid as applied to a particular property, building or other structure, it is hereby provided that the application of such portion of this Ordinance to other property, buildings or structures shall not be affected thereby.

**1.1.6. Repeal of Conflicting Ordinances.** All prior ordinances or parts of ordinances of Boone County in conflict herewith are hereby repealed.

**1.1.7. Relationship to Other Laws.** Whenever regulations or restrictions imposed by this Ordinance are either more or less restrictive than regulations or restrictions imposed by any governmental authority through legislation, rule or regulations, the regulations, rules or restrictions which are more restrictive or which impose higher standards or requirements shall govern. Regardless of any other provision of this Ordinance, no land shall be used and no structure erected or maintained in violation of any State or Federal pollution control or environmental protection law or regulation.

**1.1.8. Effective Date.** This Ordinance shall be in full force and effect after its passage, approval, and publication as required by law.

## 1.2. DEFINITIONS

**1.2.1. Use of Definitions.** In the construction of this Ordinance, the definitions contained in this Ordinance shall be observed and applied, except when the context clearly indicates otherwise;

**1.2.2. Rules.** In the construction of this Ordinance, the rules contained in this Section shall be observed and applied, except when the context clearly indicates otherwise.

- A. Words used in the present tense shall include the future; and words used in the singular number shall include the plural number, and the plural, the singular.
- B. The words "shall" and "will" are mandatory and not discretionary.
- C. The word "may" is permissive.
- D. The word "lot" shall include the words "plot", "piece", and "parcel".
- E. Unless otherwise specified, all distances shall be measured horizontally, between zones, or lot line to lot line.
- F. Whenever a word or term defined hereinafter appears in the text of this Ordinance, its meaning shall be construed as set forth in the definition thereof.
- G. The masculine gender shall include the feminine and neuter.
- H. All measured distances shall be expressed in feet and shall be rounded up or down to the nearest integral foot.
- I. The word "person" shall include the words "association", "professional corporation", "limited liability partnership", "limited liability company", "estate", "governmental agency", "individual", "joint venture", "partnership", "venture", or any other legal entity.
- J. The word "building" shall include the word "structure".
- K. The phrase "used for" shall include the phrases "arranged for", "designed for", "intended for", "maintained for", and "occupied for".

**1.2.3. Definitions.** The following words and terms when used in the interpretation and administration of this Ordinance shall have the meaning set forth herein except where otherwise specifically indicated. Words and terms not defined here shall be defined as specified in the latest published edition of Webster's New Collegiate Dictionary.

**Accessory Structure:** Shall mean a structure customarily subordinate to and auxiliary to the use of a principal structure on the same lot with such principal structure. When the wall of an accessory structure is a part of or joined to the wall of the principal structure such accessory structure shall be construed as a part of the principal structure.

**Adult Uses:** See Section 4.7.

**Agriculture:** Shall mean (1) the production of livestock, livestock products, and/or crops in the open, or land devoted to a natural resource, soil conservation, forestry management, or similar program. Not included is land principally used for residences, commerce or industry; or, (2) Land used for agricultural purposes includes the growing of farm crops, truck garden crops, animal and poultry husbandry, apiculture, aquaculture, dairying, floriculture, horticulture, nurseries, tree farms, sod farms, pasturage, viticulture, and wholesale greenhouses when such agricultural purposes constitute the principal activity on the land (see "Farm").

**Agricultural Land, Prime:** Shall mean land with a score of 76 or higher for the Land Evaluation portion of the LESA System, as rated by the Boone County Soil and Water Conservation District.

**Agricultural Land, Marginal Prime:** Shall mean land with a score of 58 or higher, but less than 76, for the Land Evaluation portion of the LESA System, as rated by the Boone County Soil and Water Conservation District.

**Agricultural Structure:** Shall mean a structure on agricultural land designed and constructed for agricultural purposes (see “Agriculture”).

**Agricultural Processing Plant:** Shall mean a facility used for the refinement, treatment, or conversion of agricultural products where physical, chemical, or similar change of an agricultural product occurs. Agricultural processing shall not include manufacturing of secondary products using agricultural products such as commercial kitchens, bakeries, breweries, woodworking, and wood processing plants. Agricultural processing may include warehousing and packaging as secondary uses.

**Agriculture, Intensive:** Shall mean agricultural uses that include but are not limited to: (a) slaughter areas, (b) areas for the storage and processing of manure, garbage, or spent mushroom compost, (c) structures housing more than one thousand (1,000) animal units; and, (d) agricultural processing plants.

**Airport:** Shall mean any area of land used or intended to be used for the landing and take off or use for airport buildings or other airport facilities or rights of way, including all necessary taxiways, aircraft storage and tie down areas, hangers, and other necessary buildings and open spaces. Refer to additional definitions in Section 4.5.

**Alley:** Shall mean a public right-of-way, with a width not exceeding twenty-four (24) feet, which affords a secondary means of access to abutting property.

**Alterations, Structural:** See “Structural Change.”

**Amusement Park:** Shall mean a commercially operated park with various devices for entertainment.

**Animal Shelter:** Shall mean any facility that shelters, feeds, grooms, and cares for homeless animals and attempts to place them in permanent adoptive homes.

**Animal Clinic:** see “Veterinary Hospital.”

**Animated Signs:** Any sign that uses movement, lighting, or special materials to depict action or create a special effect to imitate movement. This does not include signs that show time and temperature.

**Antenna:** Shall mean an arrangement of wires, metal rods, parabolic or concave dishes, or similar materials used for the transmission and/or reception of electromagnetic waves.

**Antenna Tower:** Shall mean any structure designed for the purpose of mounting an antenna.

**Artificial Lake:** Shall mean an inland body of standing water not created by natural processes.

**Assembly Hall:** Shall mean any building or part of a building whose primary use is as a meeting place for any public or private group of ten or more persons.

**Auction Sales Yards:** Shall mean building(s) or structure(s) or land(s) used for storage of goods and materials, which are to be sold on the premises by public auction, and for the sale of the said goods and materials by public auction and on an occasional basis.

**Automobile Collision Services:** Shall mean a facility for body, frame, or fender repair, and overall painting.

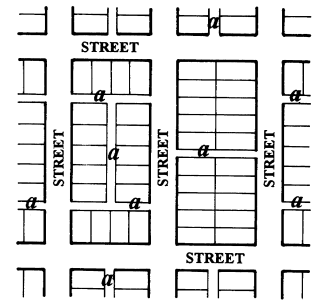

*Alley (a)*

**Automobile Repair Services:** Shall mean a facility for the general repair, rebuilding, or reconditioning of engines, motor vehicles, or trailers,. This use excludes collision repair, dismantling or salvage.

**Automobile Service Station:** Shall mean any building or premises used for dispensing, sale, or offering for sale any automotive fuels stored in underground tanks or oils and including minor (incidental) accessories and servicing of automobiles when rendered wholly within lot lines. An automobile service station does not include automobile repair, automobile collision repair, auto and trailer sales, and the outdoor storage of automobile wreckage and parts.

**Awning:** Shall mean a roof-like cover that is temporary in nature and which projects from the wall of a building for the purpose of shielding a doorway or window from the elements.

**Balcony:** Shall mean an elevated platform open to the elements, not supported by the ground and projecting from an upper story and enclosed entirely by a railing.

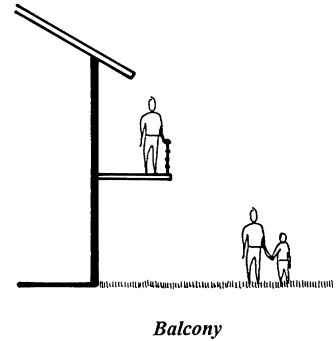

**Bar:** Shall mean a room(s) or a counter accessory to the principal use of the building or tenant space in the building where alcoholic beverages are served for consumption on the premises and may provide for dancing.

**Basement:** Shall mean a space within a building which has one-half or more of its floor-to-ceiling height below the average level of the adjoining ground and with a floor-to-ceiling height of not less than six and one-half (6.5) feet.

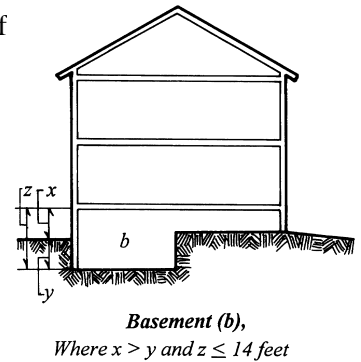

**Bay Window:** Shall mean a window projecting beyond the wall line of the building and not supported by a foundation.

**Bed and Breakfast Establishment:** Shall mean an operator and/or owner-occupied residence providing accommodations for a charge to the public with not more than five (5) guest rooms for rent. It shall be in operation for more than ten (10) nights in a twelve month period. Breakfast may be provided to the guests only. A guest room is intended to serve not more than two (2) adults per night, for a period not to exceed fifteen (15) days. Bed and Breakfast Establishments shall not include motels, hotels, boarding houses, or food service establishments.

**Berm:** Shall mean soil of good quality, uncompacted, raised generally above the surrounding finish grade with side slopes generally no steeper than three (3) horizontal units to one (1) vertical unit (3:1); generally a man-made slope.

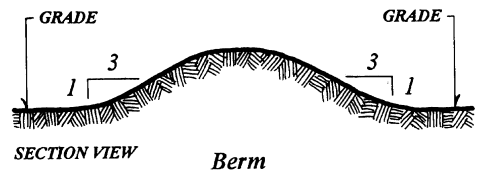

**Best Management Practices (BMP):** Shall mean conservation practices or systems and management measures that: (a) control soil loss and reduce water-quality degradation caused by nutrients, animal waste, toxins, and sediment; (b) minimize adverse impacts to surface water and groundwater flow, circulation patterns, and to the chemical, physical, and biological characteristics of wetlands; and (c) includes allowing proper use and storage of fertilizers and pesticides.

**Boarding House:** Shall mean a building containing a single dwelling unit and lodging rooms accommodating, for compensation, three (3) or more persons, but not exceeding twelve (12), who are not of the keeper's family. Lodging may be provided with or without meals.

**Breezeway:** Shall mean a covered pedestrian passageway, as between a house and a garage, but otherwise exposed to the elements.

**Buildable Area:** Shall mean the area of a lot or parcel remaining after yard, parking or any other requirements of this ordinance have been satisfied.

**Building:** Shall mean a roofed, structure designed or intended for the enclosure, shelter or protection of persons, animals or other property. All forms of vehicles, even if immobilized, are excluded from this definition.

**Building Coverage:** Shall mean the area of a lot occupied by the principal building(s) and accessory structures.

**Building Line:** Shall mean a line parallel to adjacent property lines at a specified distance from said property lines establishing the minimum open space to be provided between building(s) and an adjacent lot line. Also known as "building setback line" or "setback line."

**Building Height:** Shall mean the vertical distance of a building measured at the midpoint of the front wall of a building between the finished grade at the front wall of the building and the highest point of the roof or parapet walls, excluding chimneys, mechanical equipment, cooling towers, storage tanks, bulkheads, spires, water towers, and antennae attached to or resting upon the building.

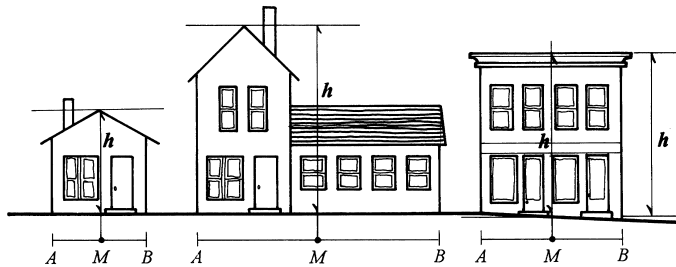

**Building Height (h)**

Where building height (h) is measured at M, the midpoint between A and B

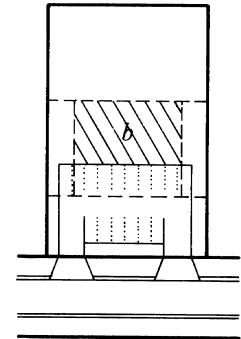

**Buildable Area (b)**

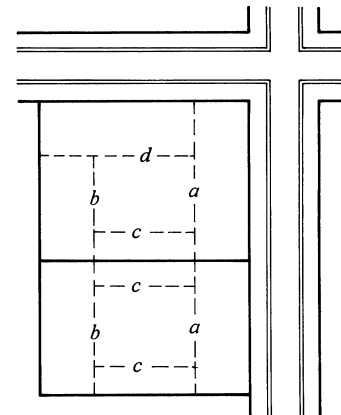

**Building Lines (Setbacks)**

Where a = Front Building Line  
 b = Rear Building Line  
 c = Side Building Line  
 d = Corner Side Building Line

**Build-to Line:** See "Building Line."

**Bulk:** Shall be the term used to describe the size and mutual relationships of buildings and other structures as to size, height, coverage, shape, location of exterior walls in relation to lot lines, to the center line of streets, to other walls of the same building, and to all open spaces relating to the building or structure.

**Burning, Controlled:** Shall mean an intentional and closely monitored grass fire which benefits plant specie diversity and soil nutrition; typically considered a normal part of prairie land maintenance conducted every few years.

**Burning, Intense:** Shall mean a rate of combustion described by a substance that burns with a high degree of activity and is consumed rapidly.

**Burning, Moderate:** Shall mean a rate of combustion described by a material which supports combustion and is consumed slowly as it burns.

**Caliper:** Shall mean the diameter of a tree trunk six (6) inches above the existing grade or proposed planted grade and in conformance with the provisions of the Code of Standards (Z60.1-1986 or latest version) published by the American Association of Nurserymen, Inc.

**Car Wash:** Shall mean a structure, or portion thereof, containing facilities for washing automobiles and may utilize production-line methods using a conveyor, blower, steam-cleaning device, or other mechanical devices, and may include detailing services.

**Cellar:** See “Basement.”

**Charitable Institutions:** Shall mean an establishment engaged in the giving of foods, goods, financial assistance or grants, or offering services or other socially useful programs on a benevolent, nonprofit basis.

**Clinic:** Shall mean an establishment of physicians or dentists, or both who have their offices in a common building.

**Cocktail Lounge:** Shall mean a room or an establishment where alcoholic beverages are served for consumption on the premises and may provide for dancing or live entertainment on the premises (excluding adult entertainment).

**Collector Street:** Shall mean a street which carries traffic from minor streets to a thoroughfare.

**Commercial Establishment:** Shall mean any place where admission, services, performances, or products are provided for or upon payment of any form of pecuniary gain.

**Commercial facility for breeding and raising non-farm fowl and animals:** Shall mean any premises or establishment that boards, breeds, raises, grooms or trains animals not classified as farm animals.

**Commercial Feed Lot:** Shall mean as defined in the Illinois State Livestock Management Facilities Act.

**Commercial Recreation:** Shall mean any establishment or use of land which provides active recreational opportunities, including but not limited to, waterslides and water parks, batting cages, miniature golf, go-cart racing, carnival games, and the like.

**Commercial Use:** Shall mean an activity carried out for pecuniary gain.

**Commission:** Shall mean the Boone County Regional Planning Commission.

**Condominium:** Shall mean an estate in real property consisting of an individual interest in common with other purchasers in a portion of real property, together with a separate interest in space in a building and/or separate interest in other portions of such real property.

**Conservation Development:** Shall mean a tract(s) of land to be developed as a single entity for a number of dwelling units, the plan for which is designed to preserve and enhance; natural systems for stormwater conveyance, infiltration, and water quality improvements; native habitat and vegetation; maintain viable agricultural activities; maintain views and vistas; and to conceal development from view from adjacent roadways and nearby properties.

**Contractors office and business:** Shall mean an enclosed space used for the housing and/or operating of machinery, the provision of services, the fabrication of building-related products and interior storage, but which does not use any exterior storage.

**Convalescent Home or Rest Home:** Shall mean an establishment for the care of the aged or infirm, or a place of rest for those suffering bodily disorders, but excluding contagious or communicable diseases and excluding surgery.

**Conventional Development:** Shall mean a development or subdivision that is not a conservation development or planned development (PD).

**Conventional Energy System:** Shall mean an energy system utilizing fossil fuel, nuclear, or hydroelectric energy and components of such system, including transmission lines, burners, furnaces, tanks, boilers, related controls, distribution systems, room or area units, and other components.

**Cooking Facilities:** Shall mean any area within a structure that contains a gas or electric range, an oven (not including a microwave oven), a refrigerator in excess of 5 cubic feet in size, and a kitchen sink.

**Crawl Space:** Shall mean the space between the ceiling of one story and the floor of the next story above, which normally contains pipes, ducts, wiring and lighting fixtures and permits access but is too low for an individual to stand. A crawl space may be a cellar area no more than four and one-half (4.5) feet in height, or, if between a ceiling and a shed roof or a flat roof, a cockloft.

**Cul-de-sac:** Shall mean a short street having one end open to traffic and being terminated at the other end by a vehicular turn-around.

**Day Care Center:** Shall mean a facility commonly called "infant and toddler centers", "child care centers", "day nurseries", "nursery schools", "play groups", "kindergartens", and "after school programs for young school age children" licensed by the Illinois Department of Children and Family Services.

**Day Care Home:** Shall mean a residence licensed by the Illinois Department of Children and Family Services for the care of at least three (3) but not more than twelve (12) children for less than twenty-four (24) hours per day. The maximum number of children permitted includes the family's natural, foster or adopted children and all other persons under the age of twelve. The term does not include residences or facilities which receive only children from a single household.

**Deciduous:** Shall mean plants which do not retain leaves or needles during the winter season of the year.

**Deck:** Shall mean a level, unenclosed platform serving as a floor and located above the finished grade, and usually directly adjoining or attached to a building or structure.

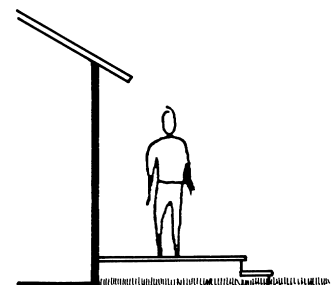

Deck

**Disability:** Shall mean a personal condition which is: (i) attributed to mental, intellectual, or physical impairment or a combination of mental, intellectual, or physical impairments; (ii) likely to continue for a significant amount of time or indefinitely; and, (iii) results in functional limitation in three or more of the following areas of major life activities self-care; recaptive or expressive language; learning; mobility; self-direction; capacity for independent living; economic self-sufficiency; and reflects the person's need for a combination and sequence of special interdisciplinary or generic care treatment, or other service of life-long or extended duration, but is not the result of a communicable disease or substance abuse or alcohol abuse.

**District, Zoning:** Shall mean a section of the areas of Boone County within which the regulations governing the use of land are uniform.

**Development Envelope:** Shall mean the area of a lot where site disruption will occur, including grading areas, building area, paved areas, utilities, yards and other areas on Non-native vegetation and areas devoted to on-site septic systems.

**Drive-Through Window:** Shall mean an opening in the wall of a building or structure used to provide sales and/or service to patrons who remain in their vehicles.

**Dwelling:** Shall mean a building or group of rooms designed or used primarily for residency, but not including hotels, motels, boarding houses, tourist homes, or trailers.

**Dwelling, Accessory Unit:** Shall mean a residential dwelling unit, but not a mobile home, located on the same lot as a single-family dwelling unit, either within the same building as the single-family dwelling unit or in a detached building. Secondary dwelling units shall be developed in accordance with the standards set forth in the ordinance.

**Dwelling, Attached Single-Family:** Shall mean a building consisting of dwelling units each of which is attached by common vertical wall to at least one other dwelling unit with each dwelling unit having a separate exterior entrance and occupying the ground, including, but not limited to, the following: "townhouse", "rowhouse", "duplex", "four-plex", "three-plex". In addition, no dwelling unit or portion thereof within an attached dwelling shall be located above or below another dwelling unit, and each dwelling unit shall have its primary access to the outside on the ground floor.

**Dwelling, Apartment:** Shall mean a building or portion thereof in which a dwelling unit or a portion thereof is located above or below another dwelling unit, or above or below any other independently used portion of the building.

**Dwelling, Detached Single-Family:** Shall mean a free-standing building containing one dwelling unit.

**Dwelling, Duplex:** Shall mean a building containing two (2) dwelling units where one (1) dwelling unit is joined with the other dwelling unit on one (1) side by a common wall. No dwelling unit or portion thereof within a duplex dwelling shall be located above or below another dwelling unit. Each dwelling unit shall have an exterior entrance located on the ground floor.

**Dwelling, Efficiency:** Shall mean a dwelling unit consisting of not more than one habitable room together with cooking and sanitary facilities.

**Dwelling, Farm:** Shall mean a single-family detached residence for those (a) resident owners or (b) immediate family members, of a farm. Resident's primary income must be from the farm activities on-site. For purposes of this definition, a "farm" is the land, buildings, and machinery used in the commercial production of agricultural products.

**Dwelling, Mobile Home:** See "Mobile Home."

**Dwelling, Multiple-Family:** Shall mean a building, or portion thereof, consisting of three (3) or more dwelling units with varying arrangements of entrances and party walls and one or more of the dwelling units do not occupy the ground, including but not limited to the following: "apartment", "condominium", "cooperative", "manor home", "coach house", "three-flat", and "six-flat".

**Dwelling, Rooming House:** Shall mean a building or a portion thereof utilized as a dwelling unit which is the primary residence of the owner and which contains lodging rooms for occupancy at a monthly rate of compensation by permanent residents who are not related to the owner. A rooming house maintains a common household. Rooming house dwellings include boarding houses and lodging houses, but exclude residential care facilities.

**Dwelling, Single-Family:** Shall mean a building containing one (1) dwelling unit only, including factory built (manufactured) dwelling units when installed on permanent foundations and issued building permits.

**Dwelling, Two-Family:** Shall mean a building consisting of two (2) dwelling units where one dwelling unit is located on the first floor and the second dwelling unit is located on the second floor and each dwelling may or may not have a separate exterior entrance.

**Dwelling Unit:** Shall mean one (1) or more rooms including a bedroom, with not more than one kitchen, which are arranged, designed or used as living quarters.

**Easement:** Shall mean a legal, recorded grant by a property owner for the use of a strip or parcel of his land by the general public, a corporation, or a certain person(s) for a specific purpose(s).

**Eave:** Shall mean the projecting lower edges of a roof, overhanging the wall of a building.

**Energy Facility:** Shall mean any public or private processing, producing, generating, storing, transmitting, or recovering facility for electricity, natural gas, petroleum, coal, or other sources of energy.

**Energy System, Small Scale:** Shall mean energy production facilities that are incidental and subordinate to a principal use established on the property. These systems include but are not limited to, solar, wind, water hydrologic, and biomass systems. This does not apply to a facility that produces more than 1.0 Megawatts (1,000,000 watts) of electricity.

**Evergreen:** Shall mean plants which continuously retain leaves or needles over four seasons of the year.

**Extended Care Facility:** Shall mean an institution or a distinct part of an institution which is licensed or approved to provide health care under medical supervision for twenty-four (24) or more consecutive hours to two or more patients.

**Fair Grounds:** Shall mean an area where outdoor fairs, circuses, or exhibitions are held.

**Family:** Shall mean (1) one (1) or more persons related by blood, marriage, or adoption (including foster children), together with such relatives of the respective spouses who are living with the family in a single dwelling and maintaining a common household; (2) not more than three (3) persons not so related, provided that such unrelated persons live in a single dwelling and maintain a common housekeeping unit; (3) any domestic servants and not more than one gratuitous guest residing with the family with such servants and guest being included, not in addition to, the unrelated persons herein defined.

**Farm:** Shall mean the land, buildings, and machinery used in the commercial production of farm products, and "farm products" are those plants and animals and their products which are produced or raised for commercial purposes. For purposes of this Ordinance, "farm" does not include property which is primarily used for residential purposes even though some farm products may be grown or farm animals bred or fed on the property incidental to its primary use. Also see "Agriculture."

**Farm, Animals:** Shall mean animals commonly raised or kept in an agricultural environment including, but not limited to horses, mules, donkeys, burros, cattle, sheep, goats, llamas, emus, rheas, ostriches, rabbits, chinchilla, turkeys, chickens, pheasants, geese, ducks and pigeons.

**Farm Machinery:** Shall mean any equipment related to the operation of any farm.

**Feed Lot:** Shall mean any parcel of land or premises on which the principal use is the concentrated feeding within a confined area of cattle, hogs, sheep, or poultry. Also see, "Agriculture, Intensive."

**Flood Plain:** Shall mean those areas along rivers and streams subject to periodic flooding. The flood plain is defined by the Flood Boundary and Floodway Map prepared by the Federal Insurance Administration and dated November 17, 1982, Community Panel Number 170807 or as amended thereafter. (Refer to Section 3.13 of this Ordinance for other definitions relevant to the Flood Plain Requirements).

**Floor Area** (for determining off-street parking and loading requirements and floor area ratios): Shall mean the sum of the gross horizontal area of the several floors of the building, or portion thereof, devoted to such use, including accessory storage areas located within selling or working space, such as counters, racks, or closets, and any basement floor area devoted to retailing activities, to the production or processing of goods, or to business or professional offices.

**Foot Candle:** Shall mean a unit of illumination equal to the illumination at all points that are one (1) foot from a uniform point source of one (1) candle power.

**Forest Management:** Shall mean the application of sustainable business methods and forestry principles to the operation of a forest property for the purpose of maintaining forest resources and producing a continuous supply of forest products. Forest management practices include, but are not limited to, site preparation, planting, selective cutting or harvesting, road construction, insect and disease control, inventory and fire protection.

**Frequency:** Shall mean the number of oscillations per second in a sound wave and is an index of the pitch of the resulting sound.

**Frontage:** Shall mean that part of a lot (a lot line) abutting a street or public way. Where buildings exist on the lot, the principal frontage may be established by the orientation of the building, or the main entrance.

**Garage, Private:** Shall mean an accessory building or an accessory portion of the principal building which is intended for and used to store the private vehicles and/or possessions of the family or families' resident upon the premises.

**Grade:** Shall mean the average level of the finished surface of the ground adjacent to the exterior walls of the building or structure.

**Greenhouse, Commercial:** Shall mean a light-admitting enclosure used for the cultivation or protection of plants for which any fee is charged.

**Greenhouse, Private:** Shall mean an enclosure used for the cultivation or protection of plants used exclusively by the occupants of the building to which it is accessory and involving no sales of goods and/or services.

**Gross Developable Acreage (GDA):** Shall mean the portion or dimension of a given property remaining after subtracting those portions which cannot be developed due to floodplain, wetlands, water retention/detention, poor soils, or other sensitive natural features which should be preserved.

**Ground Floor Area:** Shall mean the area of a building in square feet, as measured in a horizontal plane at the ground floor level within its largest outside dimensions, exclusive of open porches, breezeways, terraces, garages, and exterior stairways.

**Group Home:** Shall mean a place where unrelated adults reside in which care, treatment, or services above the level of room and board, but not including nursing care, are provided to persons residing in the facility. Group Homes do not include convents, orphanages and monasteries. The limitation of occupation is based on building code requirements.

**Habitable Space:** Shall mean space in a structure designed for living, sleeping, eating or cooking, but excluding bathrooms, toilet compartments, closets, halls, storage or utility spaces and similar areas.

**Health Club:** Shall mean a facility designed for the major purpose of physical conditioning and fitness or weight reduction which includes, but is not limited to such equipment as free weights, weight resistance machines, cardiovascular machines, whirl pools, saunas, showers, lockers, swimming pools, or basketball and racquet courts. This shall not include government owned recreation buildings.

**Health and Welfare Facility:** Shall mean a facility specializing in medical treatment, physical therapy (alcohol and drug treatment), assisted living for all ages, retirement communities, and shelters.

**Highway, Public:** Shall mean a right-of-way established to afford the movement of vehicular traffic, and including all types of classifications.

**Highway, State / County / Township:** Shall mean public highways including existing and proposed routes, but not including platted minor subdivision streets.

**Home-Based Business:** Shall mean a business, profession, occupation or trade conducted for pecuniary gain entirely within a residential building, or, when permitted by this Ordinance, within a structure that is accessory to a residential building.

**Hotel:** Shall mean a building which provides a common entrance, lobby, halls and stairways and which is open to transient guests. It provides customary hotel services such as maid service, furnishing and laundering of linen, telephone and secretarial or desk service, and the use and upkeep of furniture.

**Hunting and Fishing Lodges:** Shall mean the furnishing of rooms or accommodations for compensation that may include facilities for the preparation of food, for the purposes of public or private hunting of wildlife and/or fishing for a period of less than 30 days.

**Industrial Park:** Shall mean a tract of land planned and developed as a distinctive unit featuring landscaped open spaces of generous dimensions and equipped to accommodate a community of industrial uses including industrial research, light industry, offices and similar operations. May be sponsored and maintained by private developers, community organizations, or government organizations.

**Joint Solar Energy System:** Shall mean a solar energy system that supplies energy for structures or processes on more than one lot or in more than one condominium unit or leasehold, but not to the general public and involving at least two owners or users.

**Junk Yard:** Shall mean an area open or enclosed where waste or scrap materials are brought, sold, exchanged, stored, baled, packed, disassembled, or handled including but not limited to scrap iron and other metals, paper, rags, rubber tires and bottles. In no case shall any oil, grease, solvents, or any other chemicals be allowed to run off into drainage areas, percolate into the soil, or be discharged into septic systems; or shall the facility handle or process hazardous materials. The junk yard shall be enclosed by a solid wall or fence at least six (6) feet in height and with landscaping around those portions of the property facing a public roadway or highway. A "Junk Yard" includes a Motor Vehicle Salvage Yard (see definition).

**Kennel, Boarding or Breeding:** Shall mean any premises or portion thereof, on which four (4) or more dogs, cats, or other domestic animals are kept for the purpose of sale, boarding, training, or breeding, for which any fee is charged. This shall not apply to a Veterinary Hospital or Animal Shelter.

**LESA (Agricultural Land Evaluation and Site Assessment System):** Shall mean a system designed to determine the quality of land for agricultural uses and to assess sites or land areas for their agricultural economic viability.

**Livestock:** Shall mean generally accepted outdoor farm animals (i.e., cows, goats, horses, pigs, barnyard fowl, etc.) not to include cats, dogs and other house pets.

**Livestock, Large:** Shall mean livestock weighing two hundred fifty (250) pounds or more, and older than twelve (12) months.

**Livestock, Small:** Shall mean livestock weighing less than two hundred fifty (250) pounds and older than twelve (12) months.

**Loading Berth:** Shall mean a space logically and conveniently located for bulk pickups and deliveries, scaled to delivery vehicles expected to be used.

**Local Recycling Station:** Shall mean a structure or area used exclusively for the short-term storage and transfer of household recyclable such as, but not limited to, paper, aluminum, glass and plastic. All storage shall be within enclosed containers or a building. A local recycling station is considered a permitted accessory use to municipal or government buildings.

**Lodge or Private Club:** Shall mean a non-profit association of persons, who are bona fide members paying dues, which owns, hires or leases a building, or portion thereof, the use of such premises being restricted to members and their guests, but not including any activity defined as an “adult use.” The affairs and management of such lodge or private club are conducted by a board of directors, executive committee, or similar body chosen by the members. It shall be permissible to serve food and meals on such premises providing adequate dining room space and kitchen facilities are available. The sale of alcoholic beverages to members and their guests shall be allowed provided it is secondary and incidental to the promotion of some other common objective of the organization, and further provided that such sale of alcoholic beverages is in compliance with the applicable federal, state and local laws.

**Logistics Facility:** see “Warehouse.”

**Lot:** Shall mean a tract of land, whether legally described or subdivided as one (1) or more lots or parts of lots, located within a single block, which is to be used, developed, or built upon as a unit under single ownership or control, and having its principal frontage upon a street.

**Lot Area:** Shall mean the area of a horizontal plane bounded by the front, side and rear lot lines. Calculation of the required minimum lot area shall not include street right-of-way, whether dedicated to the public or a private street or easement for street purposes and, when adjacent a water course, drainage way, channel or stream, the area included in floodplain or easements reserved for the maintenance of said surface waters.

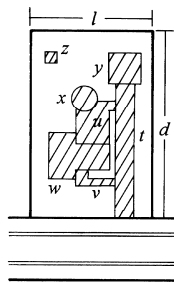

**Lot Coverage (m)**

$$\text{where } m = \frac{(t + u + v + w + x + y + z)}{\text{area of lot } (l \times d)}$$

**Lot, Corner:** Shall mean a lot which is situated at and abuts the intersection of two or more streets or adjoins a curved street at the end of a block.

**Lot Coverage:** Shall mean the percentage of a zoning lot occupied by buildings, including accessory buildings and structures, driveways, sidewalks, decks, and patios.

**Lot Depth:** Shall mean the distance between the midpoints of the front lot line and the midpoint of the rear lot line.

**Lot, Double Frontage:** Shall mean a lot which has its rear and front yard bordering on a street.

**Lot, Flag:** Shall mean a lot with access provided to the bulk of the lot by a narrow corridor of property and the narrow corridor frontage is the only public street frontage.

**Lot, Gateway:** Shall mean a lot which has its front, rear and one side yard bordering on a street.

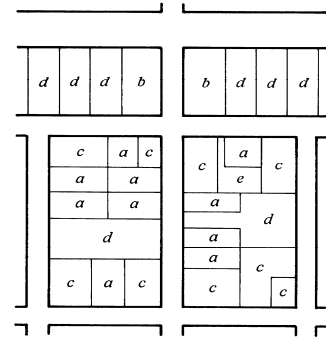

**Lots:**

- (a) Interior Lot
- (b) Gateway Lot
- (c) Corner Lot
- (d) Double Frontage Lot
- (e) Flag Lot

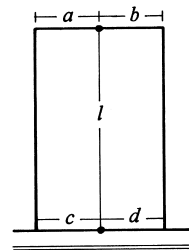

**Lot Depth (l):** where a=b and c=d

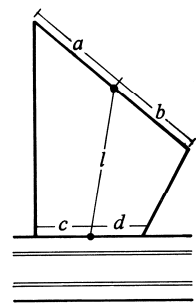

**Lot Depth (l):** where a=b and c=d

**Lot, Interior:** Shall mean a lot which has only its front yard bordering on a street.

**Lot Lines:** Shall mean a property boundary line of any lot, except that where any portion of the lot extends into abutting street or alley, the lot line shall be deemed to be the street or alley line.

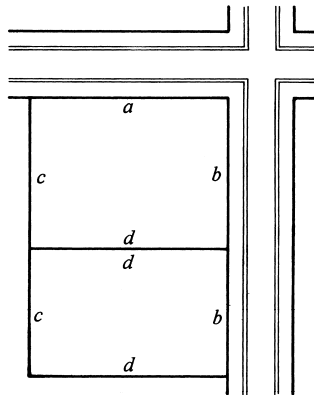

**Lot Lines:**  
(a) Corner Side Yard Line  
(b) Front Yard Line  
(c) Rear Yard Line  
(d) Side Yard Line

**Lot Line, Corner Side:** Shall mean a street right-of-way forming a side lot boundary line and not a front lot line or a rear lot line.

**Lot Line, Front:** Shall mean a street right-of-way forming a boundary of a lot. On a corner lot, the Zoning Administrator shall designate which of the two lot lines abutting a street right-of-way shall be considered a front lot line and which shall be considered a side lot line.

**Lot Line, Rear:** Shall mean a lot-line which is opposite and most distant from the front lot-line and, in the case of irregular lot lines, triangular or gore-shaped lots, a line ten feet in length within the lot, parallel to and at the maximum distance from the front lot-line.

**Lot Line, Side:** Shall mean any lot boundary line not a front lot line or a rear lot line.

**Lot of Record:** Shall mean a legally created parcel of land, the deed to which is recorded in the office of the Boone County Recorder.

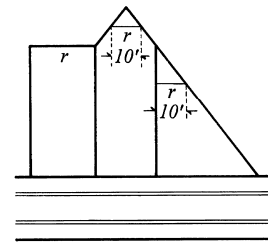

**Lot Width:** Shall mean the horizontal distance between the side lot lines of a lot measured within the lot boundary along the front building line.

**Machine Shop:** Shall mean a building or portion thereof where lathes, presses, grinders, shapers, and other wood and metal working machines are used, such as blacksmith, tinsmith welding and sheet metal shops; plumbing, heating and electrical repair shops.

**Manufactured Home:** Shall mean a mobile home that is constructed to the uniform building code developed and administered by the U.S. Department of Housing and Urban Development (HUD), can be transported on the highway and is designed as a permanent residence placed on a permanent foundation. Every manufactured home must have a minimum floor area of five hundred (500) square feet.

**Manufacturing:** Shall mean the mechanical or chemical transformation of raw materials into new products, including the assembling of component parts, or the blending of materials such as oils, plastics, resins, or liquors.

**Manufacturing and assembly, heavy:** Shall mean an establishment engaged in manufacturing, assembly, fabrication, packaging or other industrial processing of products primarily from extracted or raw materials or the bulk storage and handling of such products and materials, or an industrial establishment having potential to produce noise, dust, glare, odors or vibrations beyond its property line. This includes but is not limited to: processing and packaging alcohol beverages; chemical manufacturing; stonework or concrete production manufacturing; fabrication of metal products; manufacturing of agricultural, construction or mining machinery; motor vehicle manufacturing; lumber milling; ship or boar construction; permanent concrete/batch plant.

**Manufacturing and assembly, light:** Shall mean an establishment engaged in the indoor manufacturing, assembly, fabrication, packaging or other industrial processing or finished parts or products, primarily from previously prepared materials, or the indoor provision of industrial services, including but not limited to businesses engaged in the processing, fabrication, assembly, treatment, or

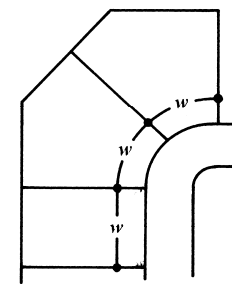

**Lot Width (w)**

packaging of food, textiles, leather, wood, paper, chemicals, plastics or metal products, but does not include basic industrial processing from raw materials.

**Mineral Extraction:** See Section 4.7.

**Minor Street:** Shall mean a street designed primarily to provide access to abutting properties.

**Mobile Home:** Shall mean a portable structure that can be transported on the highway and is designed as a single family residence. Every mobile home must have a minimum floor area of five hundred (500) square feet.

**Mobile Home Park:** See Section 4.6.

**Modular Home:** Shall mean a structure comprised of a self-sufficient dwelling unit that is transported on a vehicle from the place of manufacture to a site where it is to be occupied as a single-family dwelling. Modular homes must be of conventional stick framing, affixed to a permanent foundation and comply with all lot and yard requirements, floor area requirements, and adopted local building codes.

**Motel:** Shall mean an establishment consisting of a group of attached or detached living or sleeping accommodations with bathrooms and closet space located in a single zoning lot and designed for transient automobile tourists. A motel furnishes customary hotel services such as maid service, laundering of linen, telephone and secretarial or desk service, and the use and upkeep of furniture.

**Motor Vehicle Salvage Yard:** Shall mean an area where two or more unlicensed or inoperable motor vehicles, or parts thereof, are stored in the open and are not being actively restored to operation; or any land, building(s) or structure(s) used for wrecking or storing of such motor vehicles or parts thereof and including the commercial salvaging and sales of any goods, articles or merchandise related to the principal use.

**Motor Vehicle Storage/Impoundment Yard:** Shall mean an open area where operable and/or inoperable motor vehicles are temporarily stored for the purpose of identification, evidence inventory, repossession, etc.

**Nameplate:** Shall mean a sign indicating the name and address of a building or the name of an occupant thereof and the practice of a permitted occupation therein.

**Net Developable Area:** Shall mean the area of a tract of land after subtracting those portions which cannot be developed due to the presence of open water, floodway, floodway fringe, floodplain, wetland, soils rated as "very severe" for septic disposal systems, woodland, steep slopes (exceeding twelve-percent (12%)), or area of perimeter roadways or other land now contained in right-of-way or easements.

**Nonconforming Use:** Shall mean any use of land, buildings, or structures, lawful at the time of the enactment of this Ordinance but which does not comply with all the regulations of this Ordinance governing use for the zoning district in which such use is located.

**Nursery School:** Shall mean a building or structure, together with its lot and its accessory uses, buildings, and structures, used as an organized instructional facility or other care for five (5) or more enrolled children under six (6) years of age.

**Nursing Home:** Shall mean a place which undertakes through its ownership or management to provide maintenance, personnel, or nursing for three (3) or more persons who by reason of illness, physical deformity or old age are unable to properly care for themselves.

**Off-Road Riding Facility:** Shall mean an are of land, consisting of a closed course designed for use of off-highway vehicles in events such as, but not limited to, dirt track, short track, flat track, speedway, drag racing, grand prix, hare scrambles, hill climb, ice racing, observed trails, mud and snow scrambles, tractor pulls, sled pulls, truck pulls, mud runs, or other contests of a side-by-side

nature in a sporting event for practice, instruction, testing, or competition of off-highway vehicles; or a thoroughfare or track across land or snow used for off-highway motorcycles or all terrain vehicles

**Octave Band:** Shall mean all the frequencies from one frequency to a second frequency which is usually double the first frequency.

**Octave Band Filter:** Shall mean an electrical frequency analyzer designed according to standards formulated by the American Standards Association and used in conjunction with a sound level meter to take measurements in specific octave intervals.

**Open Sales Lot:** Shall mean any land used or occupied for the purpose of buying and selling passenger cars and/or trucks, motor scooters, motorcycles, boats, trailers, aircraft, farm machinery, or other similar products.

**Outdoor Commercial Recreation Enterprise:** Shall mean commercial recreation premises of uses conducted predominately outdoors including but not limited to driving ranges, miniature golf, swimming pools, water parks, tennis courts, outdoor racquetball courts, motorized cart and motorcycle tracks, motorized model airplane flying facility, paintball, laser tag, amusement parks, skateboard parks, basketball courts, batting cages, and trampoline facilities.

**Outdoor Shooting Ranges:** Shall mean the use of land for the discharging of firearms for the purposes of target practice, skeet and trap shooting, mock war games, or temporary competitions such as turkey shoots.

**Parking Area:** Shall mean a suitably surfaced and maintained area exclusive of any street, alley, or other access way, designed or used for the parking of motor vehicles.

**Parking Space, Off-Street:** Shall mean a space within a parking area adequate for parking an automobile with room for opening doors on both sides and proper access to a public street or alley. Each space shall be situated within the parking area so that an automobile may be parked in any space without moving another automobile.

**Particulate Matter:** Shall mean any material other than water which is suspended in or discharged into the atmosphere in a finely divided form as a liquid or solid.

**Patio:** Shall mean a level, unenclosed surfaced area located at grade and usually directly adjoining or attached to a building.

**Performance Standard:** Shall mean the criteria established to regulate uses according to the effects of their existence. Such criteria include, but are not limited to, noise, odor, smoke, toxic or noxious matter, vibration, fire and explosive hazards, and glare or heat.

**Plan:** See "Site Plan."

**Planned Development (PD):** Shall mean an area of land, controlled by a single landowner, to be developed as a single entity for a number of dwelling units, and commercial and industrial uses, if any, the plan for which does not correspond in lot size, bulk or type of dwelling or commercial or industrial use established for any zoning district. *Please see additional definitions in Section 2.10.*

**Plant Nursery:** Shall mean an area where plants are grown for transplanting, for use as stocks for building and grafting or for sale.

**Plat:** Shall mean a map or document that shows a division of land and is intended to be filed for record and which conforms to the Plat Act of the State of Illinois and with the Boone County Subdivision Regulations.

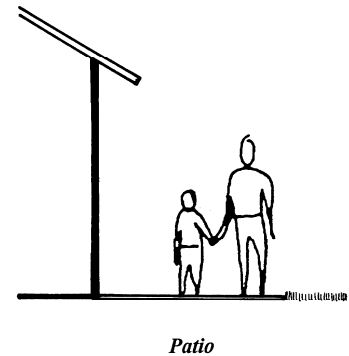

**Porch:** Shall mean a platform, built above grade, projecting from the wall of a building and having direct access to or from the building to which it is attached. A porch has no solid walls other than the wall of the building to which it is attached. A porch may be enclosed with a mesh screen to keep out unwanted insects, but is otherwise exposed to the elements throughout the year.

**Private Recreation Enterprises:** Shall mean a recreation facility open only to bona fide members and guests of the private organization operating the facility.

**Processing Plant:** Shall mean a building or an enclosed space used for the collection and processing of recyclable material. Processing means the preparation of material for efficient shipment or to an end-user's specifications, by such means as baling, briquetting, compacting, flattening, grinding, crushing, mechanical sorting, shredding, cleaning and remanufacturing.

**Public Camp:** Shall mean an area of land used or designed to be used to accommodate five (5) or more camping parties, including cabins, tents, travel trailers, or other camping outfits.

**Public Parking Area:** Shall mean a n open, hard surfaced area, other than a street or public way intended to be used for the storage of passenger automobiles and commercial vehicles under one and one-half tons capacity and available to the public, whether for compensation, free or as an accommodation, to clients, or customers.

**Recreational Vehicle:** Shall mean any vehicle or boat originally designed for living quarters, recreation, or human habitation and not used as a commercial vehicle, including, but not limited to, the following: (i) *Boats* -- meaning any vessel used for water travel, a boat mounted on a trailer shall be considered one vehicle; (ii) *Camping Trailers* -- meaning a folding or collapsible vehicle without its own motive power, designed as temporary living quarters for travel, camping, recreation or vacation use; (iii) *Motor Homes* -- meaning a temporary dwelling designed and constructed for travel, camping, recreational or vacation use as an integral part of a self-propelled vehicle; (iv) *Off-Road Vehicles* -- meaning vehicles intended primarily for recreational use off of roads, e.g. dune buggy, go-cart, dirt bike, snow mobile, 4-wheeler; (v) *Racing Car/Cycles* -- meaning vehicles intended to be used in racing competition, such as a race car or racing cycle, a racing car/cycle mounted on a trailer shall be considered one vehicle; (vi) *Travel Trailers* -- meaning vehicles without its own motive power, designed to be used as a temporary dwelling for travel, camping, recreational or vacation uses; (vii) *Truck Campers* -- meaning a structure designed primarily to be mounted on a pick-up truck or truck chassis and designed to be used as a temporary dwelling for travel, camping, recreational or vacation uses, when mounted on a truck, such structure shall be considered one vehicle; (viii) *Vans* -- meaning noncommercial motor vehicles licensed by the State of Illinois as a Recreational Vehicle; and (ix) *Vehicle Trailers* -- meaning a vehicle without its own motive power that is designed to transport another vehicle, such as a boat, motorcycle or snowmobile for recreational or vacation use and that is eligible to be licensed or registered and insured for highway use, a vehicle trailer with a vehicle mounted on it shall be considered one vehicle.

**Queuing Space:** Shall mean the reserved space occupied by any number of cars that must be accommodated while awaiting ingress or egress to specified business or service establishments.

**Recycling Collection Center:** Shall mean a use established entirely within an enclosed building where materials are received to be stored, baled, packed, disassembled, handled and made ready for bulk shipment. Recycled items are limited to paper, rags, glass, metal and plastic. Any cleaning of these items before, during or after disassembly shall entail collection of the cleaning liquid and debris in a closed bulk container and hauled off site by a licensed waste hauler. The permitted uses of such

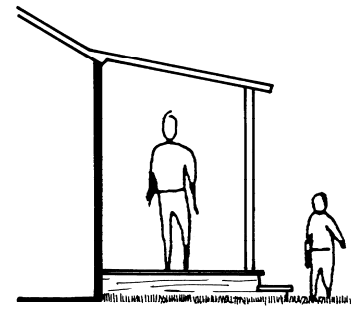

*Porch*

center do not include re-manufacturing which involves the chemical reaction of the material. This does not include the definition of "Junk Yard," defined herein, or the use of hazardous or toxic waste.

**Relative Living Quarters:** Shall mean a portion of a single-family residence, converted to include an accessory living area for elderly and/or handicapped relatives. These living quarters may not constitute a separate dwelling unit and they shall share the same utilities and same address as the primary residence.

**Residential:** Shall mean regularly used by its occupants as a permanent place of abode, which is made one's home as opposed to one's place of business and which has housekeeping and cooking facilities for its occupants only.

**Residential Property:** Shall mean any lot or other tract of land zoned for or used for residential purposes.

**Residential Subdivision:** Shall mean a development of land intended for residential use, the plat of which requires County Board approval prior to its recording. Subdivision need not be zoned residential to be considered a residential subdivision.

**Retail:** Shall mean the sale of relatively small quantities of commodities and services directly to customers.

**Right of Way (R-O-W):** Shall mean an area of land not on a lot, that is dedicated for public or private use to accommodate a transportation system and necessary public utility infrastructure, such as a street, alley, trail, water line, sanitary sewer, power or gas line. In no case shall a right-of-way be construed to mean an easement.

**Roadside Stand:** Shall mean a temporary structure used for the display and sale of agricultural products, with no space for customers within the structure itself.

**Sanitary Landfill:** Shall mean a method of disposing of refuse in a fashion that will prevent ecological degradation.

**School:** Shall mean a building or group of buildings maintained by the public or by a private organization for the purpose of education and which is accredited by the State of Illinois. Schools include grades Kindergarten through 12 but not trade schools that do not teach the State required courses for high school graduation in addition to the vocational instruction.

**Seasonal Tourist Attraction:** Shall mean a use, significantly agricultural in nature, which attracts tourism during a specific season of the year.

**Selective Cutting:** Shall mean the one-time, continuing, or cumulative removal of trees by clearing, cutting, harvesting, or other destruction, including by fire, where the extent of such activity is limited to an area (or combined areas) of less than or equal to thirty-percent (30%) of the woodlands existing on the property prior to such removal.

**Self-Service Storage Facility:** Shall mean a building or set of buildings consisting of individual rental units of space each is having its own door. Facilities may include outdoor storage spaces.

**Setback:** See "Building Line."

**Sign:** Shall mean any device (including but not limited to words, numerals, figures, emblems, pictures or any part or combination thereof) used for visual communication intended to attract the attention of the public and visible to the public right-of-way or other properties. The term sign shall not include any flag, badge, or insignia of any government unit, nor shall it include non-illuminated signs containing solely non-commercial copy such as memorial tablets.

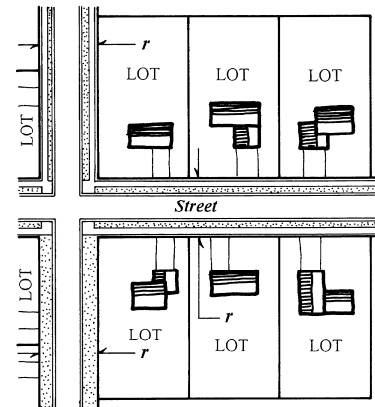

Right-of-Way (ROW) (r)

**Sign, Advertising:** Shall mean a sign which directs attention to a business, commodity, service, entertainment or other activity not exclusively related to the premises where such sign is located or to which it is affixed.

**Site, Building:** Shall mean the ground area of a building or a group of buildings together with all open spaces as required by this Ordinance.

**Sign, Business:** Shall mean a sign which directs attention to a business or profession conducted, or to a commodity, service, entertainment or other activity sold or offered upon the premises where such sign is located or to which it is affixed.

**Sight Triangle:** Shall mean a triangular area established on private property at the intersection of two (2) streets or a street and a driveway in which nothing shall be erected, planted, or allowed to grow so as to limit or obstruct the sight distance of motorists and pedestrians. See further criteria in Section 5.2.3.

**Site Plan:** Shall mean a plan drawn to scale showing uses and structures proposed for a parcel of land. The plan includes lot lines, streets, landscape features, buildings, off-street parking and loading, and utilities as required by the regulations.

**Slaughterhouse:** Shall mean (1) an Intensive Agricultural Use; (2) Any building or premises used for the killing or dressing of cattle, sheep, swine, goats, horses or poultry and the storage, freezing and curing of meat and preparation of meat products.

**Solar Energy:** Shall mean radiant energy received from the sun at wavelengths suitable for heat transfer, photosynthetic use, or photovoltaic use per Section 1.2 of The Comprehensive Solar Energy Act of 1977.

**Soil Suitability:** Shall mean that determined by "Predicted Soil Rating Sheet for Septic Suitability in Boone County-Reference #101" on file with the Boone County Health Department and Boone County Soil & Water Conservation District Office.

**Special Event:** Shall mean a temporary permitted use of land or a structure not to exceed three (3) calendar days above and beyond the permitted use. Examples include, but are not limited to, block party, festival, celebration, concert, or similar occurrence or event to be conducted for a charitable, historical, educational or public/civic purpose.

**Stable:** Shall mean a structure which is located on a lot and which is designed, arranged, used or intended to be used for housing horses for the private use of the lot owner.

**Stable, Commercial:** Shall mean a building where horses are regularly kept for remuneration, hire, sale, boarding or riding.

**Steep Slopes:** Shall mean more than one (1) foot of elevation change for every 8.33 horizontal feet; a slope of twelve-percent (12%) grade or more.

**Story:** Shall mean that part of a building between any floor and the floor next above, and if there is no floor above, then the ceiling above. A basement is a story if more than one-half of its height is above the average grade of the lot, or it is used for business purposes, or if it contains any dwelling unit.

**Street:** Shall mean a right-of-way established by a recorded plat to provide the primary means of access to abutting property.

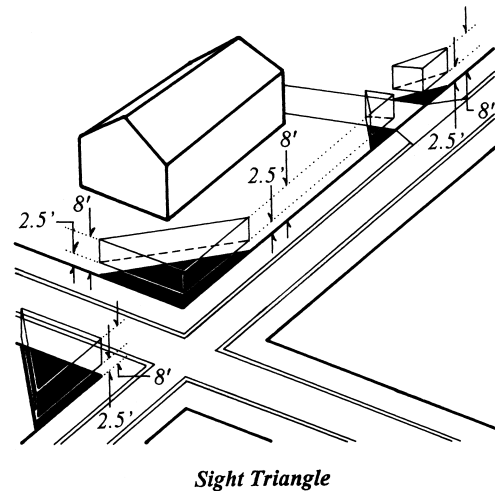

**Structural Change:** Shall mean any change or repair, other than incidental repairs, in the supporting members of a building or structure, or in the roof or exterior walls, which would prolong the life of the building or structure.

**Structure:** Shall mean anything constructed or erected that requires location on the ground or attachment to something having location on the ground. A sign, billboard, light poles, television, cell or radio towers, or other advertising medium detached or projecting shall be considered to be a structure. See also, Agricultural Structure.

**Subdivision:** Shall mean any division of land into two (2) or more parts. Any subdivision which creates a parcel of land of less than five (5) acres in size that does not comply with the Illinois Plat Act 765 ILCS 205/0.01 *ab. sec.* shall comply with the Boone County Subdivision Regulations.

**Thoroughfare:** Shall mean a public right-of-way with a high degree of continuity and serving as an arterial traffic way.

**Trade School:** Shall mean a school conducted as a commercial enterprise for teaching industrial or technical skills.

**Trailer:** Shall mean any structure standing on wheels, towed, hauled or propelled by another vehicle, and used for short-term (not permanent) human occupancy, carrying materials, goods, or objects, or as a temporary office.

**Truck Stop:** Shall mean a facility providing a full level of services to interstate truckers, inter-city bus operators, passengers and the automotive public. The center dispenses gas and diesel fuel, provides mechanical repairs, tire sales and associated services. It provides rest room and shower facilities, restaurant, convenience store, gift shops, money transfer services, check cashing, and lottery sales. The center may be operated on a 24-hour basis and can provide a truck laundry and overnight truck parking.

**Ultralight:** shall mean a powered air vehicle that is used or intended to be used for manned operation in the air by a single occupant weighs less than two hundred fifty-four (254) pounds empty weight, excluding floats and safety devices which are intended for deployment in a potentially catastrophic situation, has a fuel capacity not exceeding five (5) U.S. gallons, is not capable of more than fifty-five (55) knots (63 mph) calibrated airspeed at full power in level flight, and has a power-off stall speed which does not exceed twenty-four (24) knots (28 mph) calibrated airspeed (also known as a single-place).

**Use:** Shall mean the purpose or activity for which the land, or building thereon, is designed, arranged, or intended, or for which it is occupied or maintained.

**Use, Accessory:** Shall mean a subordinate use which is clearly and customarily incidental to the principal use of a building or premises and which is located in the same lot as the principal building or use, except for such accessory facilities as are specifically authorized to be located elsewhere.

**Use, Permitted:** Shall mean a use allowed in a particular district or districts as a matter of right, provided it conforms to all requirements, regulations, and standards of such district.

**Use, Principal:** Shall mean the main use of land or buildings as distinguished from a subordinate or accessory use.

**Use, Special:** Shall mean a use, either public or private, which, because of its unique characteristics, cannot be properly classified as a permitted use in a particular district or districts. After due consideration, in each case, of the impact of such use upon neighboring land and of the public need for particular use at the particular location, such special use may or may not be granted, subject to the terms of this Ordinance.

**Variation:** Shall mean a relaxation of the strict terms of this Ordinance where such complies with Section 2.8 of this Ordinance. A variation is only granted where a literal enforcement of this Ordinance would result in unnecessary and undue hardship.

**Veterinary Hospital:** Shall mean a place where animals or pets are given medical rehabilitation or surgical treatment and area cared for during the time of such treatment. Use as a kennel shall be limited to short time boarding and shall be incidental to such hospital use.

**Warehouse:** Shall mean a use engaged in storage, wholesale, and distribution of manufactured products, supplies, and equipment excluding bulk storage of materials that are flammable or explosive or that present hazards or conditions commonly recognized as offensive (as defined in Section 4.1.F).

**Wind Energy Conversion System (WECS):** Shall mean a machine that converts the kinetic energy in the wind into a usable form (commonly known as a wind turbine or windmill). See additional definitions in Section 4.8.

**Woodland:** Shall mean areas of trees whose combined canopies cover a minimum of eighty-percent (80%) of an area of one acre or more, as shown on the most recently available air photos of the County from a county-recognized flight and provider and verified by an on-site survey.

**Woodland Clearing:** Shall mean the one-time, continuing, or cumulative removal of trees by clearing, cutting harvesting, or other destruction (including by fire) of trees in an area (or combined areas) of more than thirty-percent (30%) of the woodlands on a property.

**Yard:** Shall mean an open space on a lot which is unoccupied and unobstructed from its lowest level to the sky, except for permitted yard obstructions, and which extends along a lot line and at right angles or radial thereto to a depth or width specified in the yard regulations for the district in which the zoning lot is located.

**Yard, Corner Side:** Shall mean a yard extending the full length of a corner side lot line and back to a line drawn parallel to the corner side lot line at a distance equal to the required corner side yard depth.

**Yard, Front:** Shall mean a yard extending along the full length of a front lot line and back to a line drawn parallel to the front lot line at a distance equal to the required front yard depth.

**Yard, Rear:** Shall mean a yard extending along the full length of a rear lot line and back to a line drawn parallel to the rear lot line at a distance therefrom equal to the required rear yard depth, but excluding any area encompassed within a required corner side yard.

**Yard, Side:** Shall mean a yard extending along the full length of a side lot line and back to a line drawn parallel to the side lot line at a distance equal to the required side yard, depth, but excluding any area encompassed within a required front yard or rear yard.

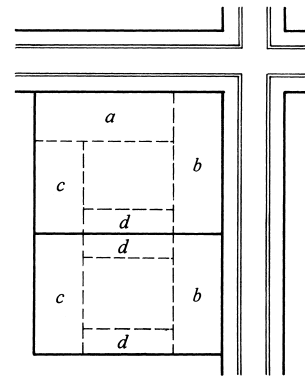

**Yards:**

- (a) Corner Side Yard
- (b) Front Yard
- (c) Rear Yard
- (d) Side Yard

**Yard, Transition:** Shall mean the required front, side, corner side or rear yard on a lot in a commercial or industrial district and an adjoining residential district, or the required front, side, corner side or rear yard for a non-residential use and adjoining residential uses in a residential district, except when such yard is adjacent a railroad right-of-way, alley or street.

**Zone:** See “District, Zoning.”

**Zoning Administrator:** Shall mean the individual designated by the County Board to administer this Ordinance, or his or her designee, per Section 2.1.

**Zoning Certificate:** Shall mean a document signed by the Zoning Enforcement Officer, as required by Section 2.4 of this code, which acknowledges that a use, structure, building, or lot either complies with or is legally nonconforming to the provisions of this zoning code, or is an authorized variation therefrom.

**Zoning Enforcement Officer:** Shall mean the individual employed by the County Board to enforce this Ordinance, or his or her designee, per Section 2.2.

**Zoning Map Amendment:** Shall mean an amendment to the map of the Boone County Zoning Ordinance, and made a part hereof in Section 3.1.3, which affects an individual parcel(s) of land.

**Zoning Text Amendment:** Shall mean an amendment to the text of the Boone County Zoning Ordinance and which affects the entire County.

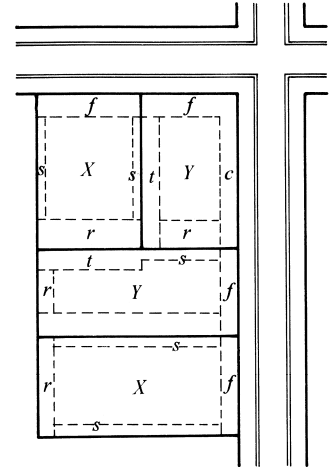

**Transition Yards (t)**

Where  
*X* = residential lot, and  
*Y* = non-residential lot

*f* = Front Yard  
*c* = Corner Side Yard  
*s* = Side Yard  
*r* = Rear Yard